



AP

1020/1520-150 150 Ton

1020/1520-100 100 Ton

ABKANT TIPI PRESLER

GARAGE TYPE
PRESS BRAKES



Manometre
Manometer

Sertleştirilmiş Bıçak
Hardened Blade



Çift El Kontrol Paneli
Two Hand Control

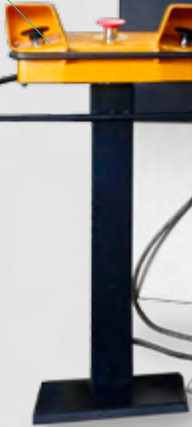

Basınç Ayar Valfi
Pressure Adjustment Valve

Ayarlanabilir Kurs
Adjustable Stroke

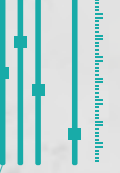

5 Ağızlı Prizma
5 Face Prism



GENEL ÖZELLİKLER

- Sertleştirilmiş abkant bıçakları
- Çelik konstrüksiyon kaynaklı gövde
- 5 Ağızlı prizma
- T-Kanallı alt tabla
- Kademesiz olarak ayarlanabilir kurs (switch)
- Basınç göstergesi (manometre)
- Ayarlanabilir alt tablalar
- Tabla indirme-kaldırma tertibatı
- İstenilen basınçta çalışma imkanı
- Büyük sacları kıvrım için büyük geçiş alanı
- Çift el ile kontrol

GENERAL FEATURES

- Hardened blades
- Steel construction welded frame
- 5-face prism
- Bottom table with T-Slot
- Stepless stroke adjustment
- Manometer
- Adjustable bottom table
- Table up-down movement attachment
- Adjustable pressure valve
- Adequate workspace for large sheets
- Two hand control



Ayarlanabilir Alt Tabla
Adjustable Bottom Table

AP
1020-150



OPSİYONEL

OPTIONAL



Çift El Kumanda Kontrolü
ve Ayak Pedali
Two Hand Control and Foot
Pedal



750mm ve 1000mm
manuel arka dayama
Manual Back Gauge
750mm or 1000mm



İsteğe Bağlı Özel Abkant
Bıçağı ve Prizma
Specific Blade and Prism

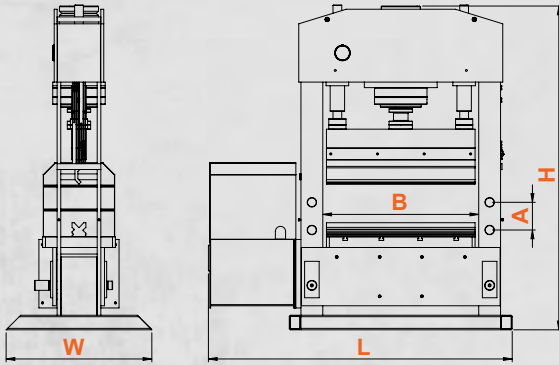

AP

			1020-100	1520-100	1020-150	1520-150
Basma Gücü	Press Power	kN	1000	1000	1500	1500
Maks. Çalışma Basıncı	Max. Working Pressure	bar	263	263	244	244
Kurs	Stroke	mm	300	300	300	300
Alt-Üst Tabla Aralığı	Top-Bottom Table Distance	mm	680	680	610	610
Kıvrırma Kapasitesi	Bending Capacity	mm	6	6	10	10
İniş Hızı	Advance Speed	mm/sec	9	9	9	9
İş Hızı	Working Speed	mm/sec	5	5	5	5
Geri Dönüş Hızı	Return Speed	mm/sec	10	10	10	10
Tabla Ölçüsü	Table Dimension	mm	500x1020	500x1520	600x1020	600x1520
Alt Tabla Merkez Deliği	Bottom Table Hole Diameter	mm	100	100	100	100
Motor Gücü	Motor Power	kW	7,5	7,5	11	11
A Delik Mesafesi	A Hole Distance	mm	190	190	190	190
B Çalışma Aralığı	B Working Area	mm	1020	1520	1020	1520
L Uzunluk	L Length	mm	2110	2630	2110	2630
W Genişlik	W Width	mm	1000	1000	1000	1000
H Yükseklik	H Height	mm	2275	2275	2450	2450
Ağırlık	Weight	kg	1900	2500	2400	3100

