

DPM

1070/1570-200 200 Ton

SABİT PİSTON
MOTORLU
FIXED PISTON
MOTORIZED

V-Yatağı
V-Blocks

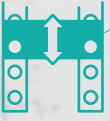

Ayarlanabilir Alt Tabla
Adjustable Bottom Table



Manometre
Manometer

Kumanda Kolu ile Kontrol
Joystick Control



GENEL ÖZELLİKLER

- Kolay kullanım imkanı
- Çelik konstrüksiyon kaynaklı gövde
- İstenilen noktada durdurma imkanı
- Basınç göstergesi (manometre)
- Aşırı yüklemelere karşı emniyet ventili
- Kumanda kolu ile kontrol
- Ayarlanabilir alt tablalar
- Tabla indirme-kaldırma tertibatı
- Takım olarak işlenmiş V-yatakları

GENERAL FEATURES

- Easy to operate
- Steel construction welded frame
- Ability to stop any position
- Manometer
- Relief valve for overloading
- Joystick control
- Adjustable bottom tables
- Table up-down movement attachment
- A pair of V-blocks

OPSİYONEL

OPTIONAL

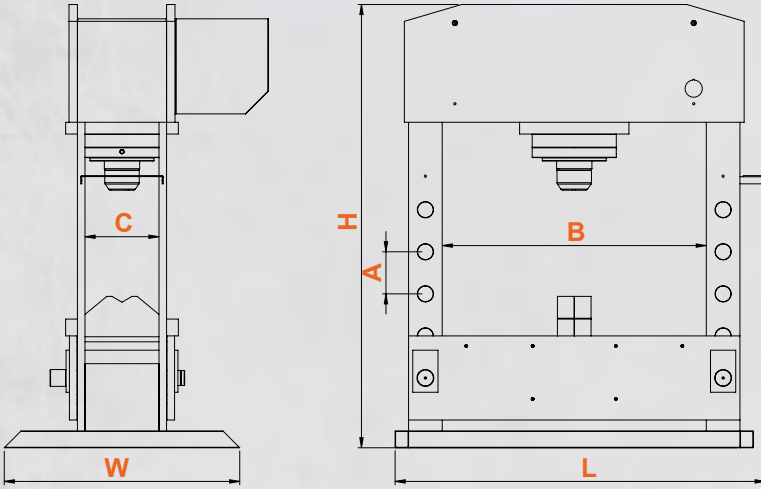

Dijital Kurs Göstergesi
Digital Stroke Read out



Ayak Pedalı
Foot Pedal



Limit Switch
Limit Switch



DPM

			1070-200	1570-200
Basma Gücü	Press Power	kN	2000	2000
Maks. Çalışma Basıncı	Max. Working Pressure	bar	283	283
Kurs	Stroke	mm	300	300
Piston Kol Çapı	Diameter of Piston Arm	Ømm	300x210	300x210
İniş Hızı	Advance Speed	mm/sec	10	10
İş Hızı	Working Speed	mm/sec	5	5
Geri Dönüş Hızı	Return Speed	mm/sec	20	20
Motor Gücü	Motor Power	kW	15	15
A Delik Mesafesi	A Hole Distance	mm	250	250
B Çalışma Aralığı	B Working Area	mm	1070	1570
C Derinlik	C Depth	mm	440	440
L Uzunluk	L Length	mm	1750	2250
W Genişlik	W Width	mm	1165	1165
H Yükseklik	H Height	mm	2860	2860
Ağırlık	Weight	kg	4050	4500

