

2019

LFSS

ŞAHİN MAKİNA SAN. VE TİC. LTD. ŞTİ.



www.lfss-sahin.com





LFSS

ŞAHİN MAKİNA SAN. ve TİC. LTD. ŞTİ.

Türkiye'nin en büyük sanayi şehirlerinden olan Bursa'da kurulan **LFSS ŞAHİN MAKİNA** geçmişten bugüne taşıdığı tecrübesi ve disiplinli çalışması ile bir çok sektörün gereksinimi olan Hidrolik Pres, Giyotin Makas, Profil & Boru Kıvrma Makinaları ve metal işleme sektörünün ihtiyaçlarına yönelik olarak diğer sac işleme makinelerini üretmektedir.

Üretiminin %80'ini yurtdışı pazarlarına yapan firmamız, Avrupa başta olmak üzere Amerika, Afrika, Uzakdoğu ve Ortadoğu ülkelerine ihracatını her geçen gün arttırmaktadır.

Hedefimiz; devamlı gelişen sektörümüzde yatırımlarımızı büyüterek marka değerimizi sürekli daha ileriye taşımaktır.

LFSS ŞAHİN MAKİNA has been established in Bursa, which is one of the biggest industrial city in Turkey, is producing the requirement machines of many sectors such as Hydraulic presses, Guillotine shears, Profile and pipe bending machines related sheet metal working machinery along with its disciplined work and experience which comes through today.

Our company exports the %80 of its production to America, Africa, Far East, Middle East and mainly to Europe and developing itself by increasing the export level by each passing day.

Our target is to increase the investments in the developing sector in order to provide constant growth in our brand.

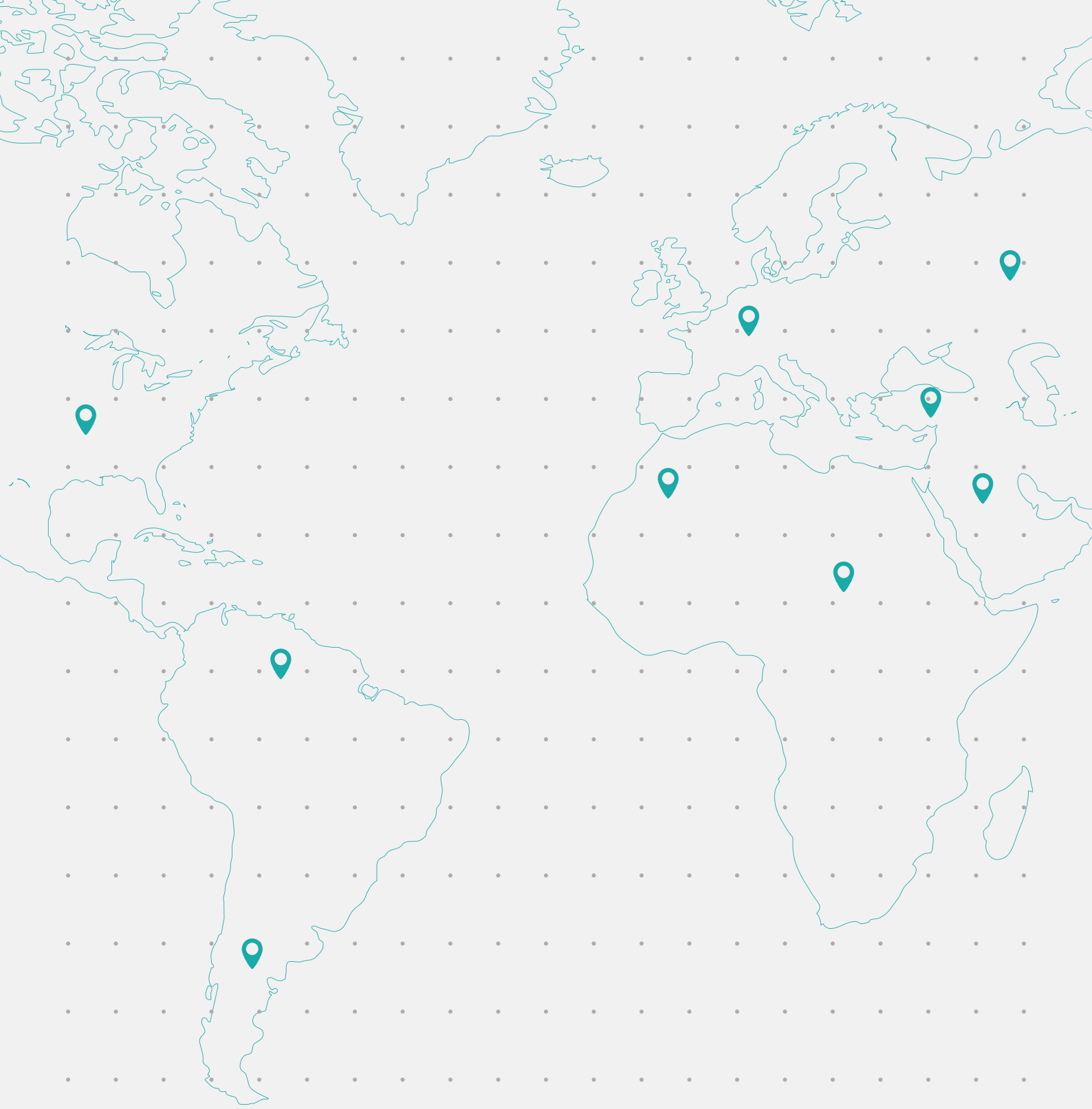

60
ÜLKEYE
İHRACAT
EXPORT
COUNTRIES

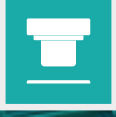

AT-S	8	DK	18
HCP	10	DPM-K	20
CFP	12	DPM	22
AT	14	DPM	24
AP	16	DP	26



LRGM	30
LRGM	32
EMGA	34
PPS	36

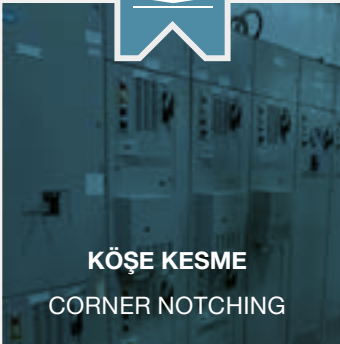
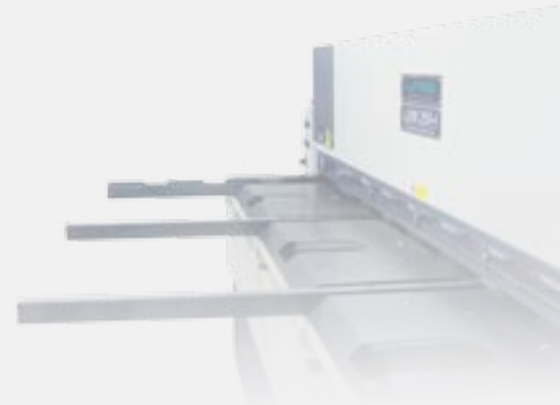

HNM 6 VP	40
HNM 6 F	42
HNM 4 F	43

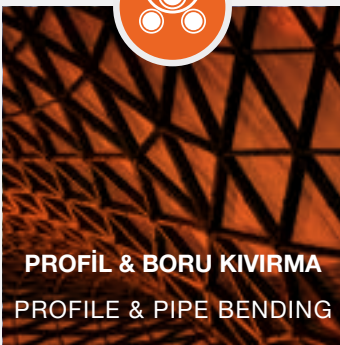
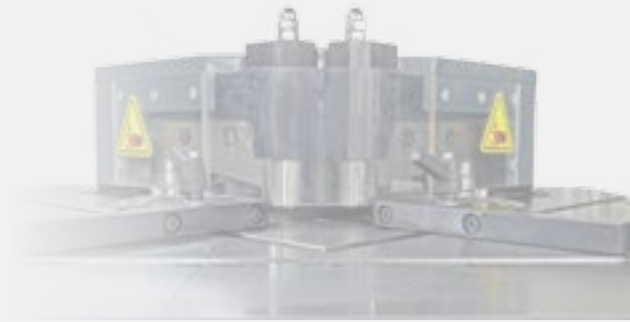

HPK 50	46
HPK 40	48
PK 35	50
PK 30	52

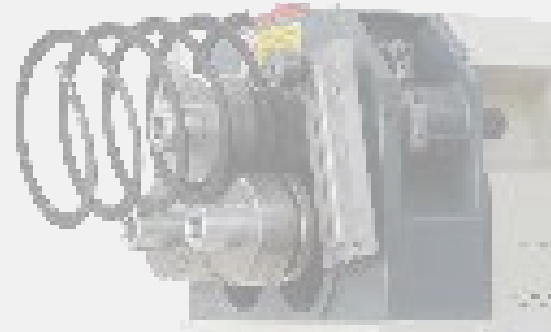



HİDROLİK PRES
HYDRAULIC PRESS



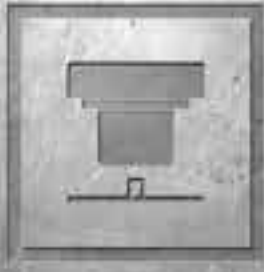

H TİPİ PRES H-FRAME PRESS

AT-S

1020/1520-150 150 Ton

1020/1520-100 100 Ton



Çift El Kontrol Paneli
Two Hand Control



Manometre
Manometer



Basınç Ayar Valfi
Pressure Adjustment Valve

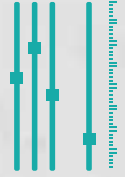

Ayarlanabilir Kurs
Adjustable Stroke



GENEL ÖZELLİKLER

- Yüksek kapasiteli H Tipi hidrolik pres. (1020 mm tek pistonlu, 1520 mm çift pistonlu)
- Çelik konstrüksiyon kaynaklı gövde
- Üst tabla yanlardan kızaklı rijitlenmiştir.
- T-Kanalı alt ve üst tabla
- Basınç göstergesi (manometre)
- Arka ve yanlarda güvenlik için koruma sacları
- Kurs; kademesiz olarak ayarlanabilir
- Basınç; kademesiz olarak ayarlanabilir
- Çift el ile kontrol

GENERAL FEATURES

- High capacity H-frame press (1020 single, 1520 double piston)
- Steel construction welded frame
- Ram table with prismatic maintenance free slide system
- T-Slot ram and bottom table
- Manometer
- Sheet cover both sides for protection
- H-Frame stepless stroke adjustment
- Pressure, stepless adjustment
- Two hand control



Acil Durum Kolu
Emergency Stop Switch



Arka Koruma
Sheet Cover for Protection

OPSİYONEL

OPTIONAL



Derin Sıvama İçin Alt Pot
Bottom Cushion For Deep Drawing

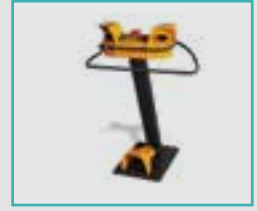

Çift El Kumanda Kontrolü ve Ayak Pedali
Two Hand Control and Foot Pedal



Işık Perdesi
Light Curtain

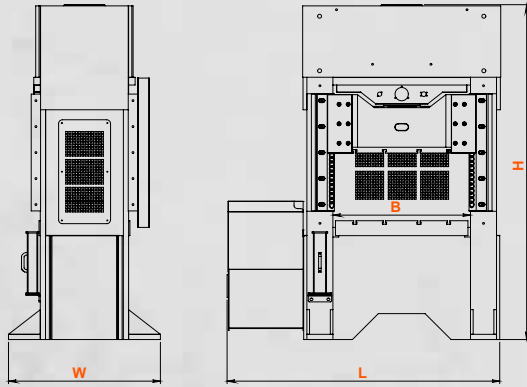

AT-S

			1020-100	1520-100	1020-150	1520-150
Basma Gücü	Press Power	kN	1000	1000	1500	1500
Maks. Çalışma Basıncı	Max. Working Pressure	bar	263	197	244	240
Kurs	Stroke	mm	300	300	300	300
Alt-Üst Tabla Aralığı	Top-Bottom Table Distance	mm	500	500	500	500
İniş Hızı	Advance Speed	mm/sec	8	10	9	10
İş Hızı	Working Speed	mm/sec	5	7,5	5	4
Geri Dönüş Hızı	Return Speed	mm/sec	10	12	10	16
Üst Tabla Ölçüsü	Ram Dimension	mm	700x1020	700x1520	700x1020	700x1520
Alt Tabla Ölçüsü	Bottom Table Dimension	mm	700x1020	700x1520	700x1020	700x1520
Alt Tabla Merkez Deliği	Bottom Table Hole Diameter	mm	100	100	100	100
Motor Gücü	Motor Power	kW	7,5	7,5	11	11
B Çalışma Aralığı	B Working Area	mm	1020	1520	1020	1520
L Uzunluk	L Length	mm	2050	2550	2050	2550
W Genişlik	W Width	mm	1170	1170	1170	1170
H Yükseklik	H Height	mm	2725	2785	2725	2785
Ağırlık	Weight	kg	6000	7800	6500	8000



HCP

30/60/100/150

C TİPİ PRES
C-FRAME PRESS



Manometre
Manometer



Basınç Ayar Valfi
Pressure Adjustment
Valve

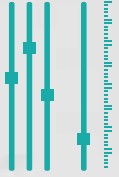

Ayarlanabilir Kurs
Adjustable Stroke



Çift El Kontrol Paneli
Two Hand Control

GENEL ÖZELLİKLER

- Çelik konstrüksiyon kaynaklı gövde
- Çift el kontrollü el kumanda
- 4 Kılavuz yataklı ana piston

GENERAL FEATURES

- Steel welded construction
- Working with two-hand control panel
- Top ram is equipped with 4 guide pistons

OPSİYONEL

OPTIONAL



İşık Perdesi
Light Curtain

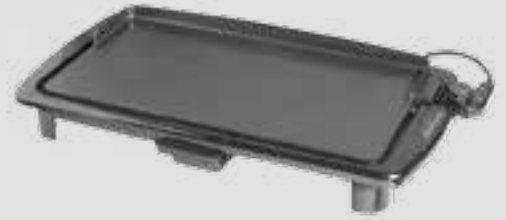
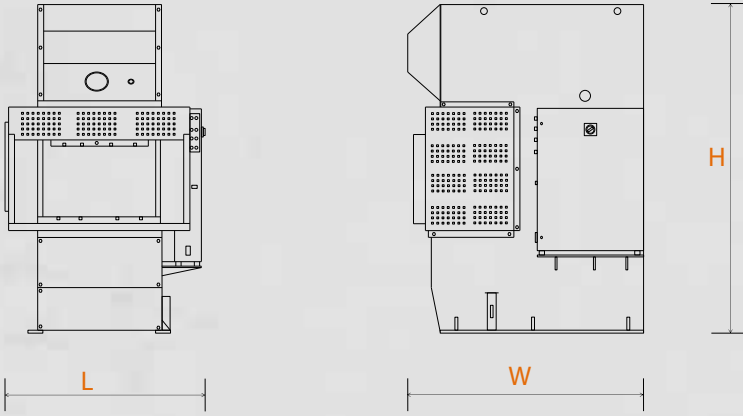

HCP

			30	60	100	150
Basma Gücü	Press Power	kN	300	600	1000	1500
Kurs	Stroke	mm	200	250	300	300
Maks. Çalışma Basıncı	Max. Working Pressure	bar	244	236	263	244
İniş Hızı	Advance Speed	mm / sec.	54	26	17,5	10
İş Hızı (Maks. Basınçta)	Working Speed (At Max. Pressure)	mm / sec.	18	8.5	5.5	3.5
Geri Dönüş Hızı	Return Speed	mm / sec.	90	47	37	22
Çene Açıklığı	Throat Depth	mm	400	450	500	500
Alt Tabla Ölçüsü	Bottom Table Dimension	mm	450x700	500x750	600x1100	700x1100
Üst Tabla Ölçüsü	Ram Dimension	mm	380x500	430x500	420x680	500x750
Merkez Uzaklığı	Center Distance	mm	200	250	260	260
Mapa Deliği	Hole on Die Table	Ømm	80	100	120	120
Motor Gücü	Motor Power	kW	7,5	7,5	7,5	7,5
Yağ Pompa Kapasitesi	Pump-Flow	lt/min	40	40	40	40
Hidrolik Tank	Oil Tank	lt	150	200	300	340
L Uzunluk	L Length	mm	1680	1820	1850	2300
W Genişlik	W Width	mm	850	960	1400	1400
H Yükseklik	H Height	mm	2250	2400	2650	2750
Ağırlık	Weight	kg	2950	4000	5400	7700

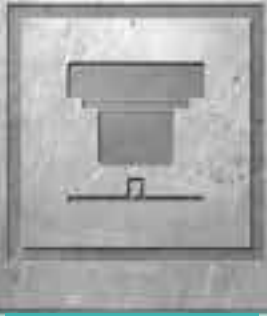

C TİPİ PRES C-FRAME PRESS

CFP

30 Ton

60 Ton

100 Ton



Ayarlanabilir Kurs
Stroke Adjustment



Manometre
Manometer



Basınç Ayar Valfi
Pressure Adjustment
Valve



GENEL ÖZELLİKLER

- Kolay kullanım imkanı
- Çelik konstrüksiyon gövde
- İstenilen noktada durdurma imkanı
- Basınç göstergesi (manometre)
- Ayarlanabilir basınç valfi
- Kademesiz olarak ayarlanabilir kurs
- T-Kanalı alt ve üst tabla
- Yanlarda iki kılavuz vazifesi gören yardımcı miller
- Koruma bariyeri
- Çift el ile kontrol

GENERAL FEATURES

- Easy to operate
- Steel construction welded frame
- Ability to stop any position
- Manometer
- Relief valve for overloading
- Stepless stroke adjustment
- T-slot top and bottom table
- Two guide piston both side
- Safety barrier
- Two hand control



Çift El Kontrol Paneli
Two Hand Control



Işık Bariyeri
Light Curtain

OPSİYONEL

OPTIONAL

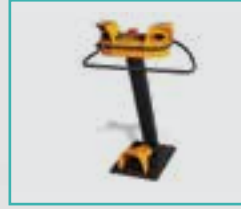

Çift El Kumanda Kontrolü ve Ayak Pedali
Two Hand Control and Foot Pedal



Işık Perdesi
Light Curtain



Abkant Bıçak Tutma Aparatı
Press Brake Tooling

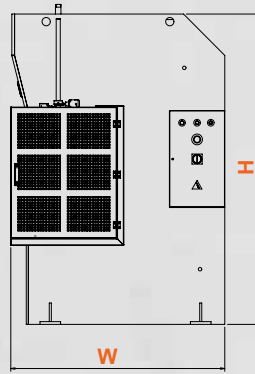
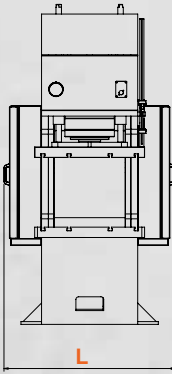

CFP

			30	60	100
Basma Gücü	Press Power	kN	300	600	1000
Kurs	Stroke	mm	400	400	400
Maks. Çalışma Basıncı	Max. Working Pressure	bar	244	236	263
İniş Hızı	Advance Speed	mm/sec	28	30	23
İş Hızı	Working Speed	mm/sec	5.5	6	5.5
Geri Dönüş Hızı	Return Speed	mm/sec	23	47	27
Çene Derinliği	Gap Depth	mm	880	880	650
Merkez Uzaklığı	Throat Depth	mm	650	650	420
Çalışma Uzunluğu	Working Length	mm	700	700	800
Alt Tabla Ölçüsü	Bottom Table Dimension	mm	600x700x45	600x700x45	530x800x75
Üst Tabla Ölçüsü	Top Table Dimension	mm	350x700x45	350x700x45	350x800x45
Merkez Deliği	Hole Diameter	mm	100	100	100
Motor Gücü	Motor Power	kW	3	7.5	11
Yağ Tankı	Oil Tank	lt	90	90	130
L Uzunluk	L Length	mm	1150	1230	1250
W Genişlik	W Width	mm	1550	1570	1570
H Yükseklik	H Height	mm	2200	2250	2250
Ağırlık	Weight	kg	2620	3520	5400





AT

1020/1520-150 150 Ton

1020/1520-100 100 Ton

**ÜNİVERSAL
T-KANALLI
HİDROLİK PRES**
UNIVERSAL T-SLOT
HYDRAULIC PRESS

Ayarlanabilir Kurs
Adjustable Stroke



Manometre
Manometer



Basınç Ayar Valfi
Pressure Adjustment
Valve



Çift El Kontrol Paneli
Two Hand Control



GENEL ÖZELLİKLER

- Kalıp bağlamak için T-Kanallı alt ve üst tablalar
- Çelik konstrüksiyon kaynaklı gövde
- Yanlarda iki ilave kılavuz vazifesi gören miller
- Ayarlanabilir alt tabla
- Tabla indirme-kaldırma tertibatı
- İstenilen basınçta çalışma imkanı
- Basınç göstergesi (manometre)
- Kademesiz olarak ayarlanabilir kurs (switch)
- Çift el ile kontrol

GENERAL FEATURES

- T-Slot top-and bottom table
- Steel construction welded frame
- Two guide piston both side
- Adjustable bottom table
- Table up-down movement attachment
- Adjustable pressure valve
- Manometer
- Stepless stroke adjustment
- Two hand control

Ayarlanabilir Alt Tabla
Adjustable Bottom Table

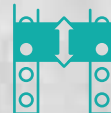

AT
1020-150



OPSİYONEL

OPTIONAL



Çift El Kumanda Kontrolü
ve Ayak Pedalı
Two Hand Control and Foot
Pedal



Abkant Bıçak Tutma Aparatı
Press Brake Tooling

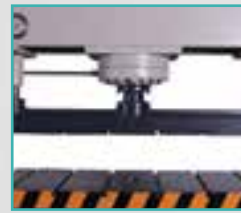

İsteğe Göre Özel
T-Kanalı Tablalar
Specific T-Slot Tables

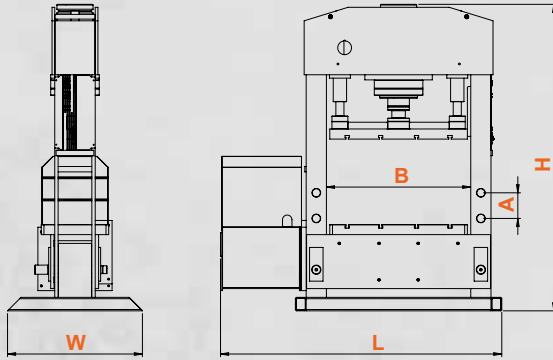

AT

			1020-100	1520-100	1020-150	1520-150
Basma Gücü	Press Power	kN	1000	1000	1500	1500
Maks. Çalışma Basıncı	Max. Working Pressure	bar	263	263	244	244
Kurs	Stroke	mm	300	300	300	300
Alt-Üst Tabla Aralığı	Top-Bottom Table Distance	mm	680	680	610	610
İniş Hızı	Advance Speed	mm/sec	8	8	9	9
İş Hızı	Working Speed	mm/sec	5	5	5	5
Geri Dönüş Hızı	Return Speed	mm/sec	10	10	10	10
Alt Tabla Ölçüsü	Bottom Table Dimension	mm	500x1020	500x1520	600x1020	600x1520
Alt Tabla Merkez Deliği	Bottom Table Hole Diameter	mm	100	100	100	100
Motor Gücü	Motor Power	kW	7,5	7,5	11	11
A Delik Mesafesi	A Hole Distance	mm	190	190	190	190
B Çalışma Aralığı	B Working Area	mm	1020	1520	1020	1520
L Uzunluk	L Length	mm	2110	2630	2110	2630
W Genişlik	W Width	mm	1000	1000	1000	1000
H Yükseklik	H Height	mm	2350	2350	2450	2450
Ağırlık	Weight	kg	1985	2500	2400	3100

AP

1020/1520-150 150 Ton

1020/1520-100 100 Ton

ABKANT TİPİ PRESLER

GARAGE TYPE
PRESS BRAKES

Sertleştirilmiş Bıçak
Hardened Blade



Çift El Kontrol Paneli
Two Hand Control



Manometre
Manometer

Ayarlanabilir Kurs
Adjustable Stroke

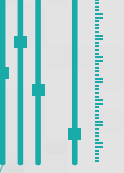

5 Ağızlı Prizma
5 Face Prism



Basınç Ayar Valfi
Pressure Adjustment Valve

GENEL ÖZELLİKLER

- Sertleştirilmiş abkant bıçakları
- Çelik konstrüksiyon kaynaklı gövde
- 5 Ağızlı prizma
- T-Kanallı alt tabla
- Kademesiz olarak ayarlanabilir kurs (switch)
- Basınç göstergesi (manometre)
- Ayarlanabilir alt tablalar
- Tabla indirme-kaldırma tertibatı
- İstenilen basınçta çalışma imkanı
- Büyük sacları kıvrım için büyük geçiş alanı
- Çift el ile kontrol

GENERAL FEATURES

- Hardened blades
- Steel construction welded frame
- 5-face prism
- Bottom table with T-Slot
- Stepless stroke adjustment
- Manometer
- Adjustable bottom table
- Table up-down movement attachment
- Adjustable pressure valve
- Adequate workspace for large sheets
- Two hand control

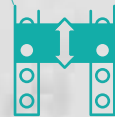

Ayarlanabilir Alt Tabla
Adjustable Bottom Table

AP
1020-150



OPSİYONEL

OPTIONAL



Çift El Kumanda Kontrolü
ve Ayak Pedali
Two Hand Control and Foot
Pedal



750mm ve 1000mm
manuel arka dayama
Manual Back Gauge
750mm or 1000mm



İsteğe Bağlı Özel Abkant
Bıçağı ve Prizma
Specific Blade and Prism

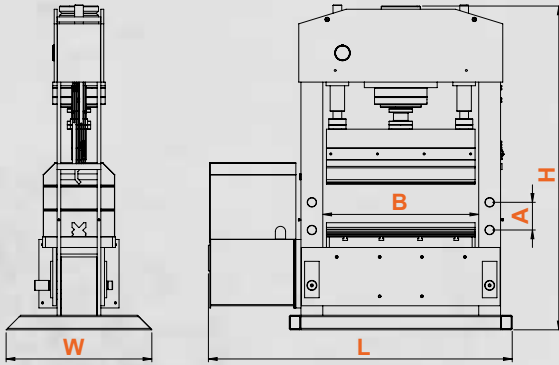

AP

			1020-100	1520-100	1020-150	1520-150
Basma Gücü	Press Power	kN	1000	1000	1500	1500
Maks. Çalışma Basıncı	Max. Working Pressure	bar	263	263	244	244
Kurs	Stroke	mm	300	300	300	300
Alt-Üst Tabla Aralığı	Top-Bottom Table Distance	mm	680	680	610	610
Kıvrırma Kapasitesi	Bending Capacity	mm	6	6	10	10
İniş Hızı	Advance Speed	mm/sec	9	9	9	9
İş Hızı	Working Speed	mm/sec	5	5	5	5
Geri Dönüş Hızı	Return Speed	mm/sec	10	10	10	10
Tabla Ölçüsü	Table Dimension	mm	500x1020	500x1520	600x1020	600x1520
Alt Tabla Merkez Deliği	Bottom Table Hole Diameter	mm	100	100	100	100
Motor Gücü	Motor Power	kW	7,5	7,5	11	11
A Delik Mesafesi	A Hole Distance	mm	190	190	190	190
B Çalışma Aralığı	B Working Area	mm	1020	1520	1020	1520
L Uzunluk	L Length	mm	2110	2630	2110	2630
W Genişlik	W Width	mm	1000	1000	1000	1000
H Yükseklik	H Height	mm	2275	2275	2450	2450
Ağırlık	Weight	kg	1900	2500	2400	3100

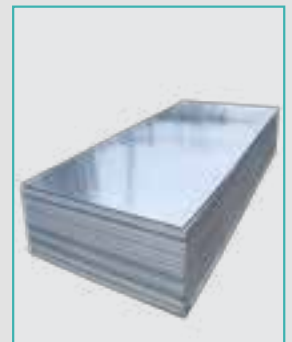

DK

1900/200 200 Ton

1570-150 150 Ton

1570-100 100 Ton

Manometre
Manometer



Yağ Tankı
Oil Tank

GEZER PİSTON

MOTORLU (AĞIR TİP)

MOBILE PISTON

MOTORIZED (HEAVY DUTY)



Kremiyerli Gezer Kafa Piston

Geared Moveable
Piston by
Hand Wheel

Ayarlanabilir Alt Tabla

Adjustable Bottom
Table

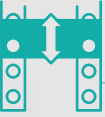

Kumanda Kolu ile
Kontrol
Joystick Control

GENEL ÖZELLİKLER

- Kolay kullanım imkanı
- Çelik konstrüksiyon kaynaklı gövde
- İstenilen noktada durdurma imkanı
- Basınç göstergesi (manometre)
- Aşırı yüklemelere karşı emniyet ventili
- Kumanda kolu ile kontrol
- Ayarlanabilir alt tablalar
- Tabla indirme-kaldırma tertibatı
- Takım olarak işlenmiş V-yatakları
- Kremiyerli gezer piston
- Özel çift hız kumanda kolu ile kontrol (DK 1570x100 ve DK 1570x150)

GENERAL FEATURES

- Easy to operate
- Steel construction welded frame
- Ability to stop any position
- Manometer
- Relief valve for overloading
- Joystick control
- Adjustable bottom tables
- Table up-down movement attachment
- A pair of V-blocks
- Geared moveable piston by hand wheel
- Dual speed joystick control (DK 1570x100 and DK 1570x150)

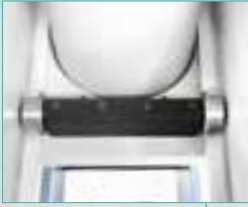

DK
1570-150



V-Yatağı
V-Blocks



OPSİYONEL

OPTIONAL



El Pompası
(200 TON Hariç)
Hand Pump
(Except 200TON)



Ayak Pedalı
Foot Pedal



Dijital Kurs Göstergesi
Digital Stroke Read out



Limit Switch
Limit Switch

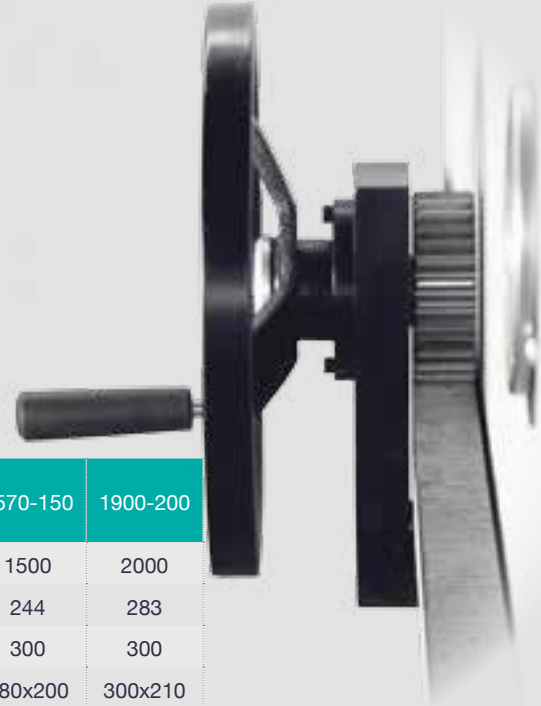
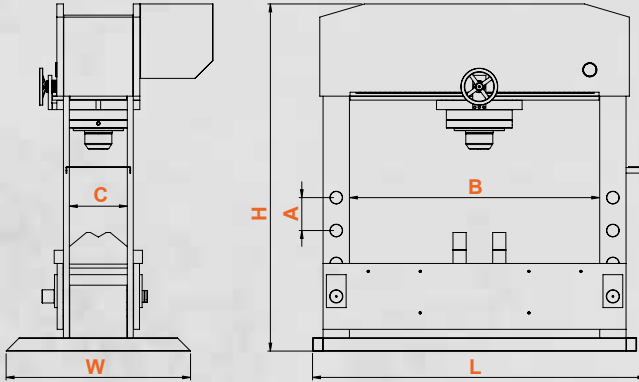

DK

			1570-100	1570-150	1900-200
Basma Gücü	Press Power	kN	1000	1500	2000
Maks. Çalışma Basıncı	Max. Working Pressure	bar	263	244	283
Kurs	Stroke	mm	300	300	300
Piston Kol Çapı	Diameter of Piston Arm	Ømm	220x160	280x200	300x210
İniş Hızı	Advance Speed	mm/sec	8	9	10
İş Hızı	Working Speed	mm/sec	5	5	5
Geri Dönüş Hızı	Return Speed	mm/sec	10	10	20
Motor Gücü	Motor Power	kW	5,5	11	15
A Delik Mesafesi	A Hole Distance	mm	190	190	250
B Çalışma Aralığı	B Working Area	mm	1570	1570	1900
C Derinlik	C Depth	mm	315	360	440
L Uzunluk	L Length	mm	2630	2630	2570
W Genişlik	W Width	mm	1000	1000	1665
H Yükseklik	H Height	mm	2625	2625	2860
Ağırlık	Weight	kg	1755	2350	4800

DPM-K

1070/1570-150 150 Ton

1040-80 80 Ton

1070/1570-100 100 Ton

1040-60 60 Ton

775 - 30 30 Ton

GEZER PİSTON
MOTORLU
MOBILE PISTON
MOTORIZED

Rulman Hareketli Gezer Piston
Ball Bearing Mobile Piston



Manometre
Manometer



Piston Hareket Kilit Mekanizması
Piston Movement Lock System



Özel Çift Hız Kumanda Kolu
Dual Speed Joystick

V-Yatağı
V-Blocks

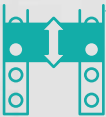

Ayarlanabilir Alt Tabla
Adjustable Bottom Table

GENEL ÖZELLİKLER

- Kolay kullanım imkanı
- Çelik konstrüksiyon kaynaklı gövde
- İstenilen noktada durdurma imkanı
- Basınç göstergesi (manometre)
- Aşırı yüklemelere karşı emniyet ventili
- Özel çift hız kumanda kolu ile kontrol
- Ayarlanabilir alt tablalar
- Tabla indirme-kaldırma tertibatı
- Takım olarak işlenmiş V-yatakları
- Rulman hareketli gezer piston

GENERAL FEATURES

- Easy to operate
- Steel construction welded frame
- Ability to stop any position
- Manometer
- Relief valve for overloading
- Dual speed joystick control
- Adjustable bottom tables
- Table up-down movement attachment
- A pair of V-blocks
- Ball bearing mobile piston



DPM-K
1040-60



OPSIYONEL

OPTIONAL



El Pompası
Hand Pump



Ayak Pedalı
Foot Pedal



Dijital Kurs Göstergesi
Digital Stroke Read out



Limit Switch
Limit Switch

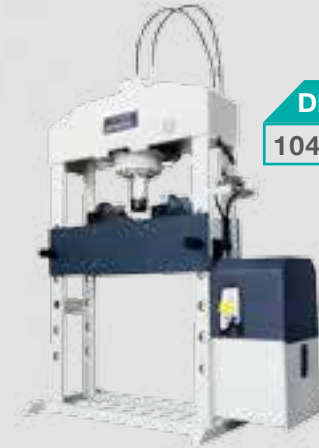
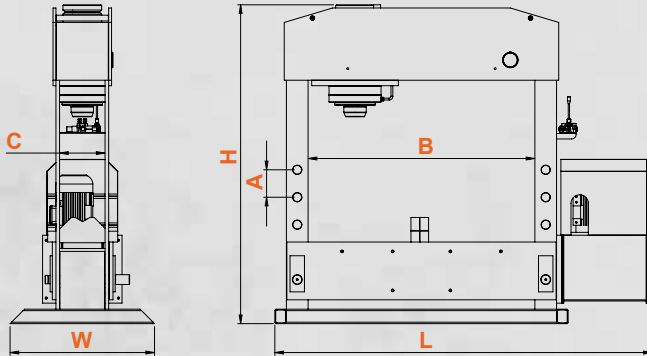

DPM-K
1040-80

			DPM-K							
			775-30	1040-60	1040-80	1070-100	1570-100	1070-150	1570-150	
Basma Gücü	Press Power	kN	300	600	800	1000	1000	1500	1500	
Maks. Çalışma Basıncı	Max. Working Pressure	bar	244	236	255	263	263	244	244	
Kurs	Stroke	mm	200	250	250	300	300	300	300	
Piston Kol Çapı	Diameter of Piston Arm	Ømm	125x80	180x120	200x120	220x160	220x160	280x200	280x200	
İniş Hızı	Advance Speed	mm/sec	7,5	8	8	8	8	9	9	
İş Hızı	Working Speed	mm/sec	5	4	5	5	5	5	5	
Geri Dönüş Hızı	Return Speed	mm/sec	10	10	10	10	10	10	10	
Motor Gücü	Motor Power	kW	3	4	5,5	5,5	5,5	11	11	
A Delik Mesafesi	A Hole Distance	mm	165	165	165	190	190	190	190	
B Çalışma Aralığı	B Working Area	mm	775	1040	1040	1070	1570	1070	1570	
C Derinlik	C Depth	mm	190	260	260	315	315	360	360	
L Uzunluk	L Length	mm	1500	1710	1810	2110	2630	2110	2630	
W Genişlik	W Width	mm	700	700	750	1000	1000	1000	1000	
H Yükseklik	H Height	mm	1800	2100	2100	2430	2430	2480	2480	
Ağırlık	Weight	kg	400	800	835	1500	1600	1870	2100	

DPM

1070/1570-200 200 Ton

SABİT PİSTON
MOTORLU
FIXED PISTON
MOTORIZED

V-Yatağı
V-Blocks

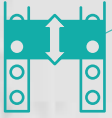

Ayarlanabilir Alt Tabla
Adjustable Bottom Table



Manometre
Manometer

Kumanda Kolu ile Kontrol
Joystick Control



GENEL ÖZELLİKLER

- Kolay kullanım imkanı
- Çelik konstrüksiyon kaynaklı gövde
- İstenilen noktada durdurma imkanı
- Basınç göstergesi (manometre)
- Aşırı yüklemelere karşı emniyet ventili
- Kumanda kolu ile kontrol
- Ayarlanabilir alt tablalar
- Tabla indirme-kaldırma tertibatı
- Takım olarak işlenmiş V-yatakları

GENERAL FEATURES

- Easy to operate
- Steel construction welded frame
- Ability to stop any position
- Manometer
- Relief valve for overloading
- Joystick control
- Adjustable bottom tables
- Table up-down movement attachment
- A pair of V-blocks

OPSIYONEL

OPTIONAL

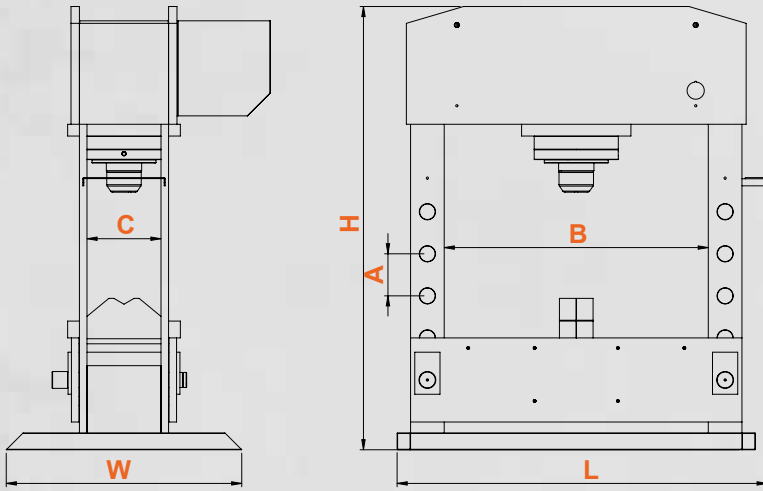

DPM

			1070-200	1570-200
Basma Gücü	Press Power	kN	2000	2000
Maks. Çalışma Basıncı	Max. Working Pressure	bar	283	283
Kurs	Stroke	mm	300	300
Piston Kol Çapı	Diameter of Piston Arm	Ømm	300x210	300x210
İniş Hızı	Advance Speed	mm/sec	10	10
İş Hızı	Working Speed	mm/sec	5	5
Geri Dönüş Hızı	Return Speed	mm/sec	20	20
Motor Gücü	Motor Power	kW	15	15
A Delik Mesafesi	A Hole Distance	mm	250	250
B Çalışma Aralığı	B Working Area	mm	1070	1570
C Derinlik	C Depth	mm	440	440
L Uzunluk	L Length	mm	1750	2250
W Genişlik	W Width	mm	1165	1165
H Yükseklik	H Height	mm	2860	2860
Ağırlık	Weight	kg	4050	4500





DPM

1070/1570-150 150 Ton

1040-80 80 Ton

1070/1570-100 100 Ton

1040-60 60 Ton

775 - 30 30 Ton

SABİT PİSTON
MOTORLU
FIXED PISTON
MOTORIZED



Manometre
Manometer



Özel Çift Hız Kumanda Kolu
Dual Speed Joystick

V-Yatağı
V-Blocks

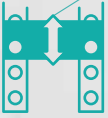

Ayarlanabilir Alt Tabla
Adjustable Bottom Table



GENEL ÖZELLİKLER

- Kolay kullanım imkanı
- Çelik konstrüksiyon kaynaklı gövde
- İstenilen noktada durdurma imkanı
- Basınç göstergesi (manometre)
- Aşırı yüklemelere karşı emniyet ventili
- Özel çift hız kumanda kolu ile kontrol
- Ayarlanabilir alt tablalar
- Tabla indirme-kaldırma tertibatı
- Takım olarak işlenmiş V-yatakları

GENERAL FEATURES

- Easy to operate
- Steel construction welded frame
- Ability to stop any position
- Manometer
- Relief valve for overloading
- Dual speed joystick control
- Adjustable bottom tables
- Table up-down movement attachment
- A pair of V-blocks

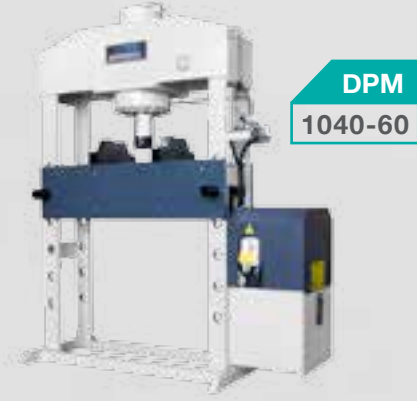

DPM
1040-60



OPSIYONEL

OPTIONAL



El Pompası
Hand Pump



Ayak Pedalı
Foot Pedal



Dijital Kurs Göstergesi
Digital Stroke Read out



Limit Switch
Limit Switch

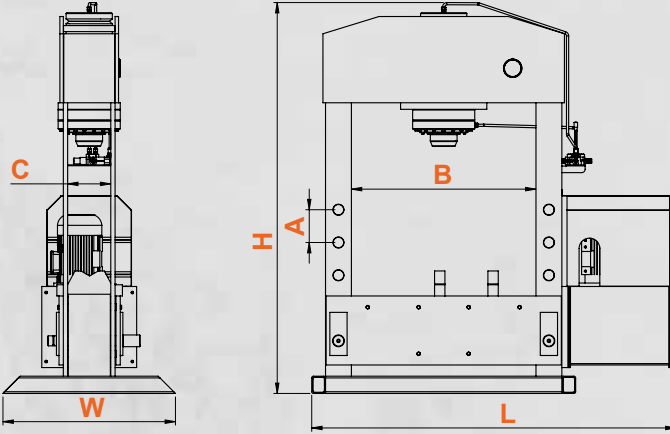

DPM
1040-80

 DPM			775-30	1040-60	1040-80	1070-100	1570-100	1070-150	1570-150
Basma Gücü	Press Power	kN	300	600	800	1000	1000	1500	1500
Maks. Çalışma Basıncı	Max. Working Pressure	bar	244	236	255	263	263	244	244
Kurs	Stroke	mm	200	250	250	300	300	300	300
Piston Kol Çapı	Diameter of Piston Arm	Ømm	125x80	180x120	200x120	220x160	220x160	280x200	280x200
İniş Hızı	Advance Speed	mm/sec	7,5	8	8	8	8	9	9
İş Hızı	Working Speed	mm/sec	5	4	5	5	5	5	5
Gerİ Dönüş Hızı	Return Speed	mm/sec	10	10	10	10	10	10	10
Motor Gücü	Motor Power	kW	3	4	5,5	5,5	5,5	11	11
A Delik Mesafesi	A Hole Distance	mm	165	165	165	190	190	190	190
B Çalışma Aralığı	B Working Area	mm	775	1040	1040	1070	1570	1070	1570
C Derinlik	C Depth	mm	190	260	260	250	250	290	290
L Uzunluk	L Length	mm	1500	1745	1810	2110	2630	2110	2630
W Genişlik	W Width	mm	700	700	750	1000	1000	1000	1000
H Yükseklik	H Height	mm	2015	2100	2100	2290	2290	2340	2340
Ağırlık	Weight	kg	400	800	835	1400	1580	1900	2100

DP

600-30 30 Ton

500-20 20 Ton

500-10 10 Ton

MANUEL KOLLU
MANUAL ARM



Manometre
Manometer

V-Yatağı
V-Blocks



Ayarlanabilir Piston Başı
Adjustable Piston Crown

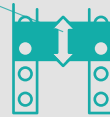

Ayarlanabilir Alt Tabla
Adjustable Bottom Table

GENEL ÖZELLİKLER

- Kolay kullanım imkanı
- Çelik konstrüksiyon kaynaklı gövde
- İstenilen noktada durdurma imkanı
- Basınç göstergesi (manometre)
- Ayarlanabilir alt tablalar
- Takım olarak işlenmiş V-yatakları

GENERAL FEATURES

- Easy to operate
- Steel construction welded frame
- Ability to stop any position
- Manometer
- Adjustable bottom tables
- A pair of V-blocks



DP
500-20



DP
500-10

MASA TİPİ
TABLE TYPE

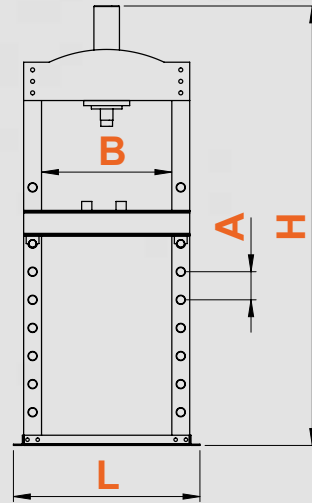
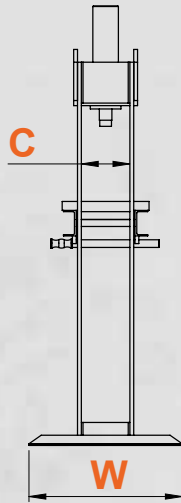

DP			500-10	500-20	600-30
Basma Gücü	Press Power	kN	100	200	300
Maks. Çalışma Basıncı	Max. Working Pressure	bar	244	244	244
Kurs	Stroke	mm	125	125	125
Piston Kol Çapı	Diameter of Piston Arm	Ømm	80	85	90
A Delik Mesafesi	A Hole Distance	mm	200	200	200
B Çalışma Aralığı	B Working Area	mm	400	400	550
C Derinlik	C Depth	mm	190	190	190
L Uzunluk	L Length	mm	610	610	750
W Genişlik	W Width	mm	500	750	650
H Yükseklik	H Height	mm	1325	1570	1790
Ağırlık	Weight	kg	100	110	160

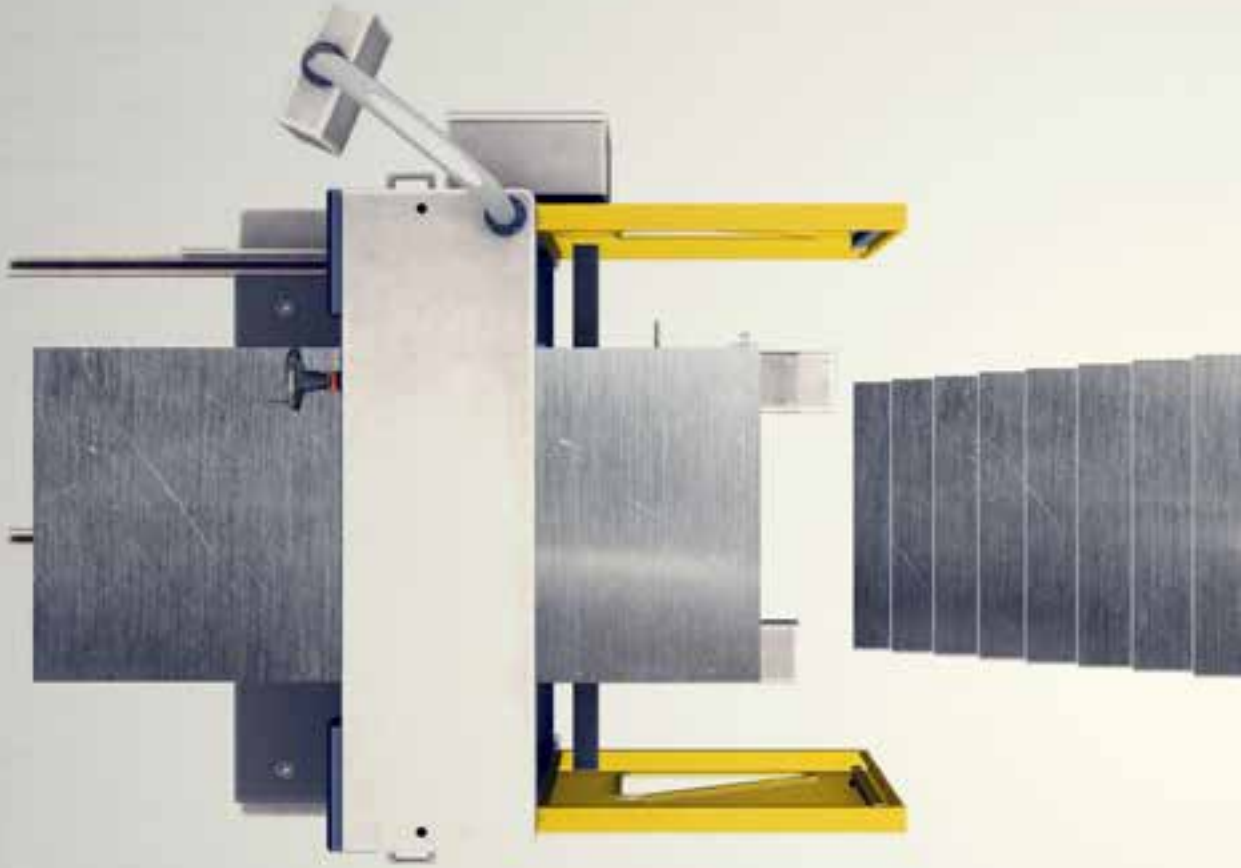

GİYOTİN MAKAS
GUILLOTINE SHEAR

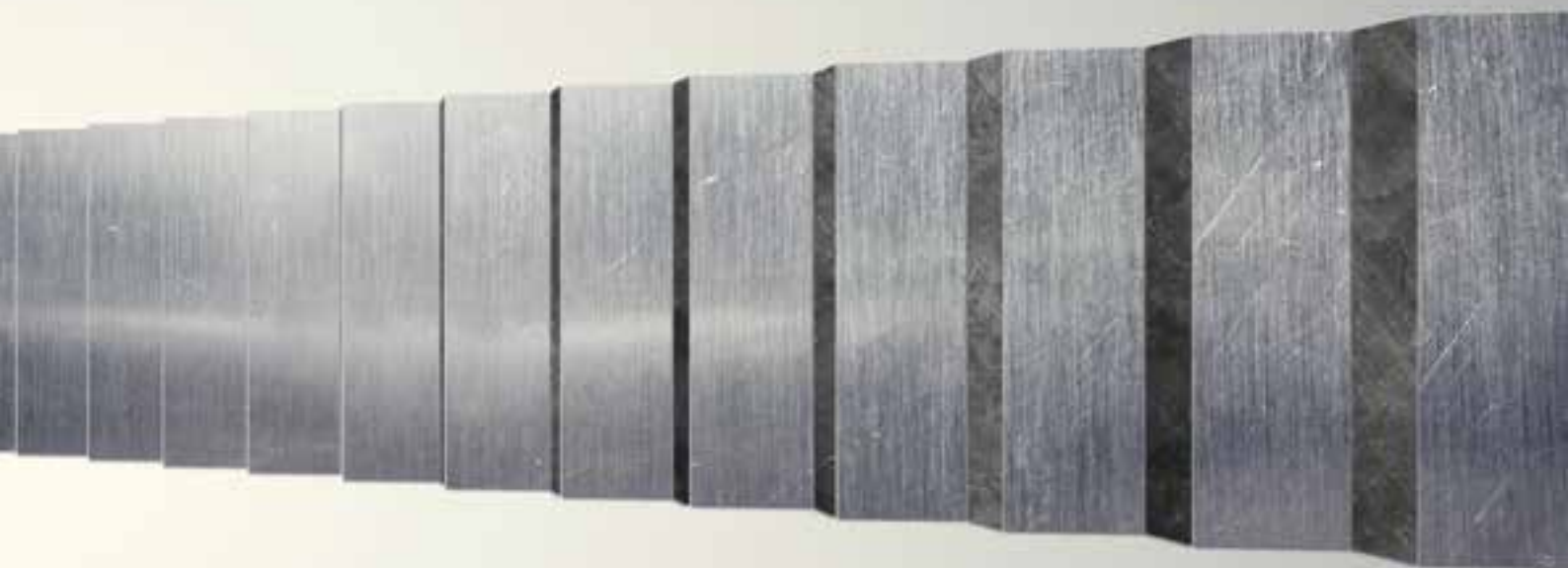



LRGM

2050 / 2550 / 3050 - 4 mm

**REDÜKTÖRLÜ
GİYOTİN MAKAS**
MECHANICAL
GUILLOTINE SHEAR



Bilyalı Ön Tabla
Ball-bearing Front Table



Parmak Koruma Bariyeri
Finger Protection



BRL NC Kontrol
BRL NC Control



Ayak Pedalı İle Kontrol
Foot Pedal Control



Tabaka Saclar İçin Ön Destek Kolları
Front Support Arms



Bıçak Sentil Ayarı
Blade Gap Adjustment

GENEL ÖZELLİKLER

- Çelik konstrüksiyon, kaynaklı gövde
- İki yüzü kullanılabilen sertleştirilmiş bıçaklar
- NC kontrollü 750mm arka dayama
- Kesim anında sacın kaymasını önleyen sac baskı sistemi
- Uzun saclar için ön destek dayama kolları (cetvel)
- Parmak koruma bariyeri
- Kesim hattı LED aydınlatması
- Ayak pedalı ile kontrol

GENERAL FEATURES

- Steel construction welded frame
- Two sided hardened blades
- Motorized 750mm NC back gauge
- Hold down system avoiding sheet sliding during operation
- Front support arms for long sheet cutting with ruler
- Finger protection
- Led lighting on cutting line
- Foot pedal control

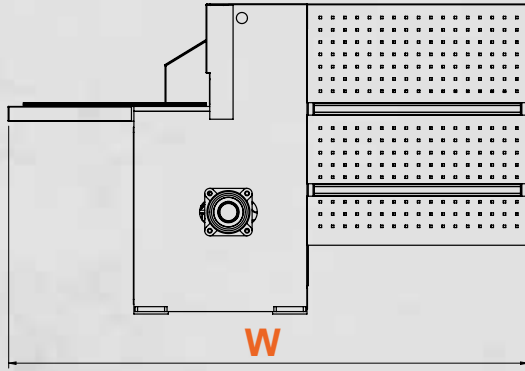
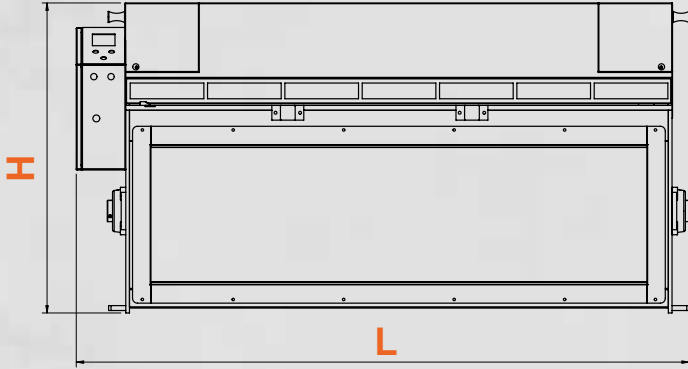

OPSİYONEL

OPTIONAL



**NC Kontrollü, Motorlu
750mm ve 1000mm
Arka Dayama**
Motorized 750mm or
1000 mm NC Back Gauge



ELGO P9521 NC



Işık Koruma Bariyeri
Light Curtain



**0-180° Ayarlanabilir
Gönye**
0-180° Angular Cutting



**Pnömatik Sac Destek
Sistemi**
Pneumatic Sheet Support

			2050 - 4	2550 - 4	3050 - 4
	LRGM				
Kesme Kapasitesi	Cutting Capacity	mm	4	4	4
Kesme Boyu	Cutting Length	mm	2050	2550	3050
Vuruş Sayısı	Stroke Per Minute	-	41	41	41
Tabla Genişliği	Table Width	mm	455	455	455
Arka Dayama Uzunluğu	Back Gauge Length	mm	750	750	750
Arka Dayama Motor Gücü	Back Gauge Motor Power	kW	0,75	0,75	0,75
Motor Gücü	Motor Power	kW	7,5	7,5	7,5
L Uzunluk	L Length	mm	2700	3200	3700
W Genişlik	W Width	mm	2150	2150	2150
H Yükseklik	H Height	mm	1450	1450	1450
Ağırlık	Weight	kg	3010	3510	4010



LRGM

1350 / 1550 / 2050 - 3 mm

2550 / 3050 - 2 mm

**REDÜKTÖRLÜ
GIYOTİN MAKAS**
MECHANICAL
GUILLOTINE SHEAR



Bilyalı Ön Tabla
Ball-bearing Front Table



Parmak Koruma Bariyeri
Finger Protection



Ayak Pedalı İle Kontrol
Foot Pedal Control



Tabaka Saclar İçin Ön Destek Kolları
Front Support Arms

GENEL ÖZELLİKLER

- Çelik konstrüksiyon, kaynaklı gövde
- İki yüzü kullanılabilen sertleştirilmiş bıçaklar
- Manuel 750mm arka dayama
- Kesim anında sacın kaymasını önleyen sac baskı sistemi
- Uzun saclar için ön destek dayama kolları (cetvel)
- Parmak koruma bariyeri
- Kesim hattı LED aydınlatması
- Ayak pedalı ile kontrol

GENERAL FEATURES

- Steel construction welded frame
- Two sided hardened blades
- Manual 750mm back gauge
- Hold down system avoiding sheet sliding during operation
- Front support arms for long sheet cutting with ruler
- Finger protection
- Led lighting on cutting line
- Foot pedal control



LRGM
NC

OPSİYONEL

OPTIONAL



**NC Kontrollü, Motorlu
750mm ve 1000mm
Arka Dayama**
Motorized 750mm or
1000 mm NC Back Gauge



**0-180° Ayarlanabilir
Gönye**
0-180° Angular Cutting



Işık Koruma Bariyeri
Light Curtain



**Pnömatik Sac Destek
Sistemi**
Pneumatic Sheet Support

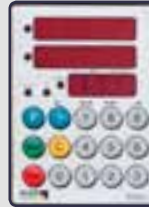
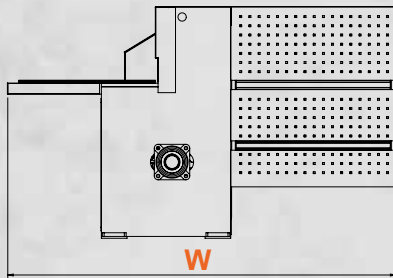
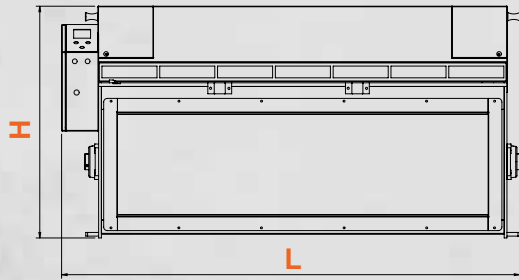

ELGO P9521 NC



BRL NC Kontrol
BRL NC Control



LRGM

			1350 - 3	1550 - 3	2050 - 3	2550 - 2	3050 - 2
Kesme Kapasitesi	Cutting Capacity	mm	3	3	3	2	2
Kesme Boyu	Cutting Length	mm	1350	1550	2050	2550	3050
Vuruş Sayısı	Stroke Per Minute	-	35	35	35	35	35
Tabla Genişliği	Table Width	mm	390	390	390	390	390
Arka Dayama Uzunluğu	Back Gauge Length	mm	750	750	750	750	750
Arka Dayama Motor Gücü	Back Gauge Motor Power	kW	0,75	0,75	0,75	0,75	0,75
Motor Gücü	Motor Power	kW	3	3	4	4	4
L Uzunluk	L Length	mm	1930	2150	2700	3200	3700
W Genişlik	W Width	mm	2150	2150	2150	2150	2150
H Yükseklik	H Height	mm	1310	1310	1310	1310	1310
Ağırlık	Weight	kg	1260	1550	1760	1960	2210



EMGA

1320 - 2,5 mm

1520 - 2 mm

**ANGRAJLI
GİYOTİN MAKAS**
MOTORIZED
GUILLOTINE SHEAR



Döküm Taşlanmış Tabla
Cast Iron Ground Table



Arka Dayama 600 mm
Back Gauge 600 mm



Tabaka Saclar İçin Ön Destek Kolları
Front Support Arms





GENEL ÖZELLİKLER

- Pik döküm ayaklar , Platina tabla ve üst çene
- Kesme anında sacın kaymasını önleyen mekanik baskı sistemi
- Üst çene için ayarlanabilir kızaklar , Dar ve ince sacların kesimine uygun arka dayama sistemi
- Dört ağızlı kullanılabilen tek parçalı 2379 çelik bıçaklar
- Kolay ayarlanabilen sentil ayar sistemi , Bıçakların üst üste binmesini önleyen bindirmezlik sistemi , Tek ve seri kesmeye elverişli ayak pedal sistemi
- Dik kesim sağlayan milimetrik gönye , Sessiz çalışan kavrama sistemi , Geniş ve açılı sac kesmeye uygun ön gönye ve ön kollar.
- Ana mil ve eksantrik kollar için okuyucu sac muhafaza , Volan için koruyucu muhafaza

GENERAL FEATURES

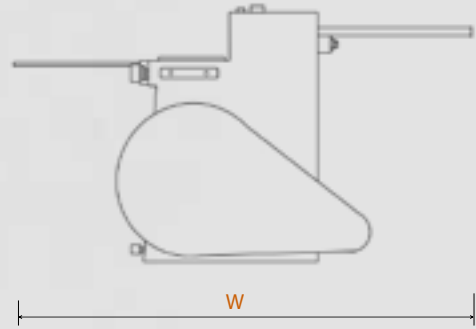
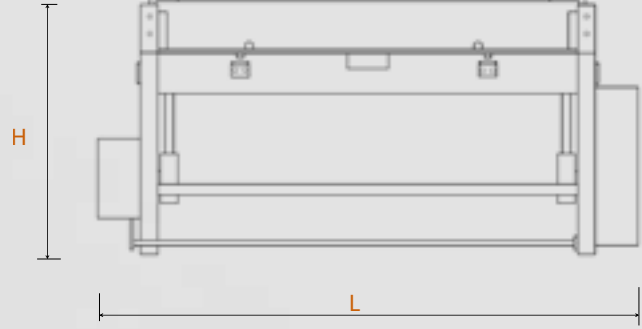
- Cast iron frames and base Steel Plate and Upper Jaw
- Mechanical Sheet fixer to avoid slipping , Adjustable sledges for Upper jaw, Adjustable back gauge for narrow and short parts
- 4 sided 2370 quality high tensile steel blades
- Easy setting of blade gap , Preventor mechanism for blades overlapping, Foot pedal system to arrange for single or multi-cuts
- Sensitive Frame to enable Clear perpendicular cuts , silent clutch system, Adjustable front gauges to enable wide piece cutting
- Sheet cover For main shaft and eccentric arms , Cover sheet for flywheel



			1320x2,5	1520x2,0
	EMGA			
Tabla Ölçüsü	Table Dimension	mm	380x1420	380x1620
Bıçak Boyu	Blade Length	mm	1310	1510
Kesme Boyu	Shearing Length	mm	1300	1500
Kesme Kapasitesi (Siyah Sac)	Shearing Capacity (Mild Steel)	mm	2,5	2,0
Kesme Kapasitesi (Paslanmaz)	Shearing Capacity (Stainless)	mm	1,2	1,0
Dakika / Kesim	Cut / Per Minute	X	80	80
Motor Gücü	Motor Power	kW	3	3
Arka Dayama Açıklığı	Back Gauge Length	mm	600	600
L Uzunluk	L Length	mm	1550	1850
W Genişlik	W Width	mm	840	840
H Yükseklik	H Height	mm	1200	1200
Ağırlık	Weight	kg	900	1200





PPS

**PNÖMATİK PEDALLI
GİYOTİN MAKAS**
PNEUMATIC OPERATED
GUILLOTINE SHEAR



Yaylı Ayak Pedalı
Foot Pedal by Spring



Ayarlanabilir Arka Dayama
Adjustable Back Gauge

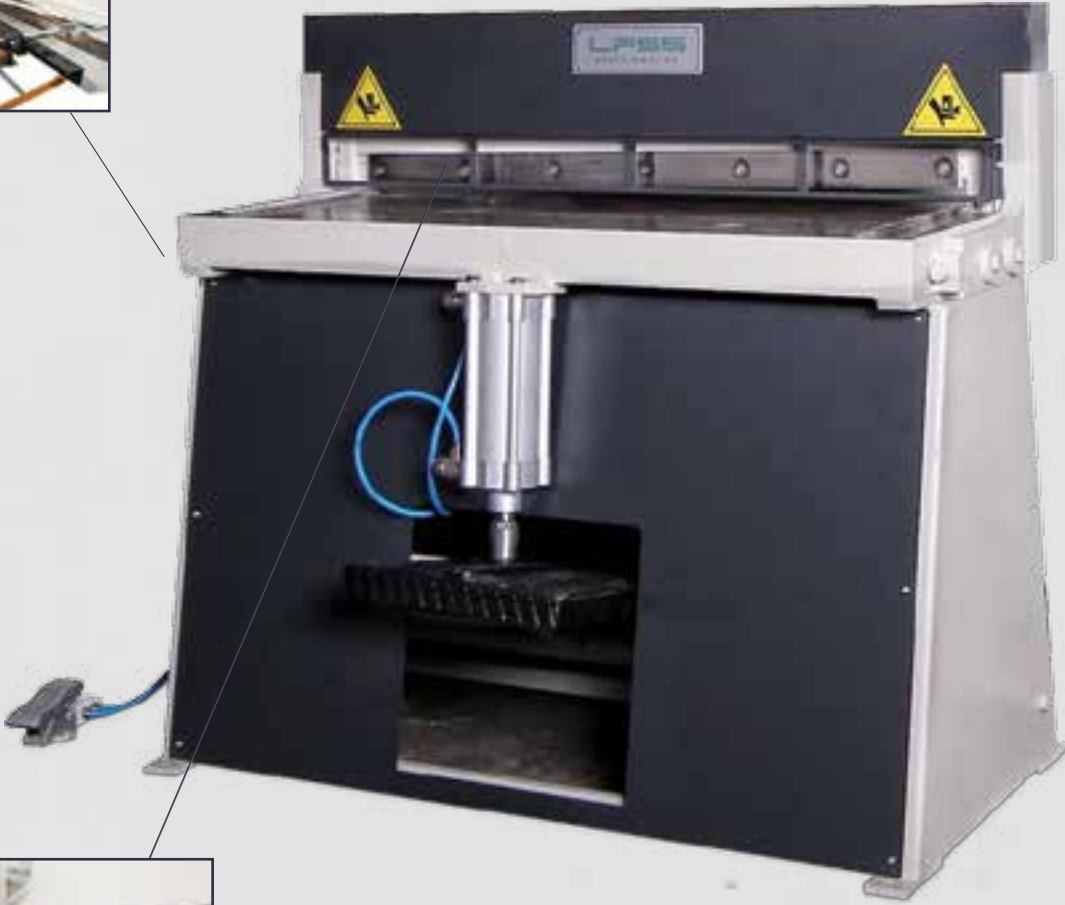

Parmak Koruma Bariyeri
Finger Protection

GENEL ÖZELLİKLER

- Kolay kullanım imkanı
- Çelik konstrüksiyon, kaynaklı gövde
- Sertleştirilmiş bıçaklar
- Ayarlanabilir ön ve arka dayama

GENERAL FEATURES

- Easy to operate
- Steel construction welded frame
- Hardened blades
- Adjustable front and back gauge

PPS
12

PPS 12



PPS
15

PPS 15

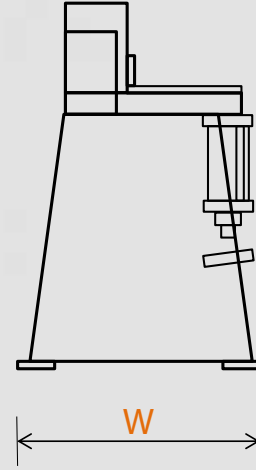
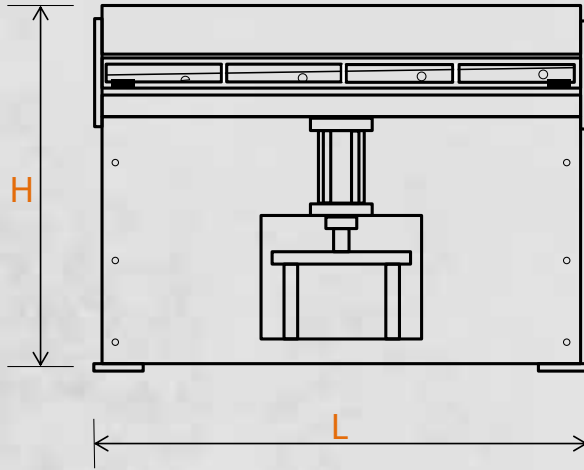

PPS			10	11	12	15
Tabla Ölçüsü	Table Dimension	mm	320x1150	300x1180	350x1470	330x1430
Bıçak Boyu	Blade Length	mm	1025	1030	1320	1320
Kesme Boyu	Shearing Length	mm	1000	1050	1300	1300
Kesme Kapasitesi (Siyah Sac)	Shearing Capacity (Mild Steel)	mm	1	1	1,2	1,5
Arka Dayama Açıklığı	Back Gauge Length	mm	500	500	610	610
L Uzunluk	L Length	mm	1550	1320	1680	1680
W Genişlik	W Width	mm	840	860	640	560
H Yükseklik	H Height	mm	1200	1200	1360	1150
Ağırlık	Weight	kg	350	380	490	600



KÖŞE KESME
CORNER NOTCHERS



HNM 6 VP

HİDROLİK AÇI AYARLI KÖŞE KESME

HYDRAULIC
VARIABLE ANGLE
CORNER NOTCHERS



Açı Ayarlı Bıçaklar
Angle Adjustable Blades



Açı Ayarlı Gönye
Angular Cutting



GENEL ÖZELLİKLER

- HNM-6 V açı ayarlı hidrolik köşe kesme makinesi statik ve dinamik rijitliği sağlanmış çelik tabla ve üst çene malzemesi ile güçlü bir yapıya sahiptir.
- Hassas şekilde kesim yapabilmek için makinenin üst tablası T- kanallı olarak işlenmiştir ve farklı sac kalınlıklarını kesmek için ayrı ayar gerektirmeyen otomatik sentil ayar sistemi ile donatılmıştır.
- 4 hidrolik baskı silindiri sayesinde sık tekrarlanabilir kesim imkanı sunmaktadır.
- Makinenin arka bölümünde bulunan ZIMBA-DELİK DELME istasyonu sayesinde çok işlevli makinadır.
- Maksimum 6 mm kalınlık kesme kapasitesi

GENERAL FEATURES

- HNM-6 V variable rake hydraulic corner notchers have a strong frame with its statically and dynamically rigid steel table and top beam material.
- T slot top table realizes precise cuttings and there is no need for alignment for different sheet thicknesses by means of automatic blade gap adjustment.
- HNM-6 V series perform frequent cutting repeatability via 4 hydraulic hold-down cylinders.
- With the Punching Station in the back of the machine it becomes to a very efficient functional machine.
- Max. 6mm thickness cutting capacity.



Zimba İstasyonu
Punch Unit

Ø14 mm Delme Kapasitesi
Ø14mm Punch Die

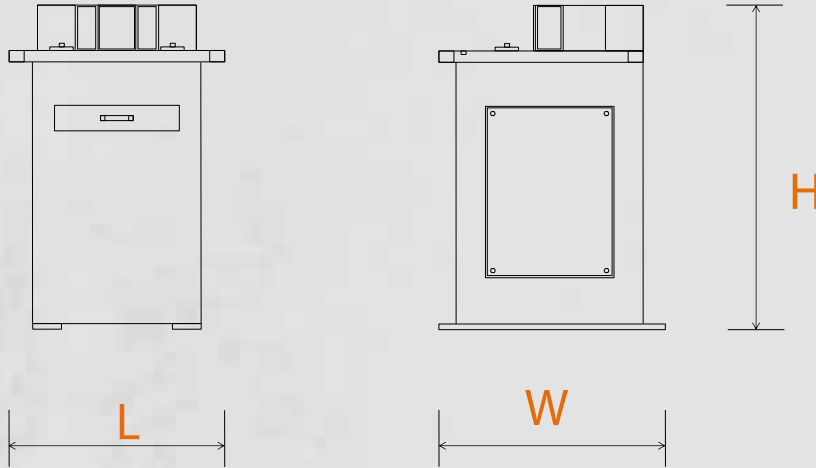

HNM

6 VP

Çelik Kesme	Steel Cutting	mm 60..140°	6 - 4
Paslanmaz Kesme	Stainless Cutting	mm 60..140°	3 - 2,5
Motor Gücü	Power	kW	4
Tabla Boyutu	Table Dimension	mm	1150x610
Kesme Açısı	Cutting Angle	°	30x140 °
Maksimum Kesme / dk.	Max. Cutting Per Minute	x	30
Bıçak Boyu	Blade Length	mm	200x200
Yağ Tank Kapasitesi	Oil Tank Capacity	lt.	35
Maksimum Çalışma Basıncı	Max. Working Pressure	bar	200
L Uzunluk	L Length	mm	1100
W Genişlik	W Width	mm	1150
H Yükseklik	H Height	mm	1200
Ağırlık	Weight	kg	1150



HNM

6 F

4 F

HİDROLİK SABİT AÇILI KÖŞE KESME

HYDRAULIC
FIXED ANGLE
CORNER NOTCHERS

HNM

6F



Sabit 90° Açılı Bıçaklar
Fixed 90° Blades



GENEL ÖZELLİKLER

- HNM-6 F sabit açılı köşe kesme makinesi 6mm'ye kadar köşe çıkarır.
- En geniş kesme ölçüleri 250x250mm.
- Sabitlenmiş 90° sayesinde hızlı köşe çıkarma.
- Az hacmi sayesinde rahat bir çalışma imkanı sunar.

GENERAL FEATURES

- The HNM-6 F hydraulic notcher can cut up to 6 mm.
- The biggest notcher size is 250x250mm.
- The notching angle axes in 90° with high notching speed.
- The hydraulic notcher has compact structure, small volume and convenient operation.

HNM
4F

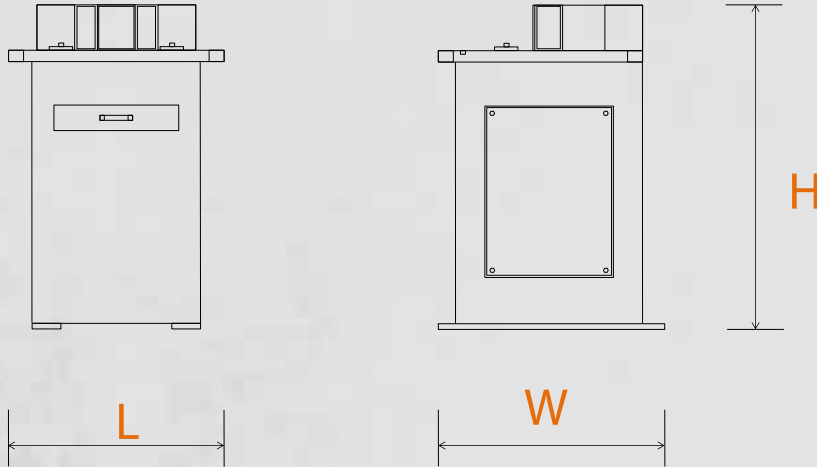

		HNM		6 F 6 mm	4 F 4 mm
Çelik Kesme	Steel Cutting	mm 90°		6	4
Paslanmaz Kesme	Stainless Cutting	mm 90°		3	2,5
Motor Gücü	Power	kW		4	4
Tabla Boyutu	Table Dimension	mm		800x750	685x590
Kesme Açısı	Cutting Angle	°		90	90
Maksimum Kesme / dk.	Max. Cutting Per Minute	x		25	50
Bıçak Boyu	Blade Length	mm		250x250	197x197
Yağ Tank Kapasitesi	Oil Tank Capacity	lt.		35	45
Maksimum Çalışma Basıncı	Max. Working Pressure	bar		200	120
L Uzunluk	L Length	mm		1010	1120
W Genişlik	W Width	mm		850	1200
H Yükseklik	H Height	mm		1400	1600
Ağırlık	Weight	kg		630	500



PROFIL & BORU KIVIRMA
PROFILE & PIPE BENDING

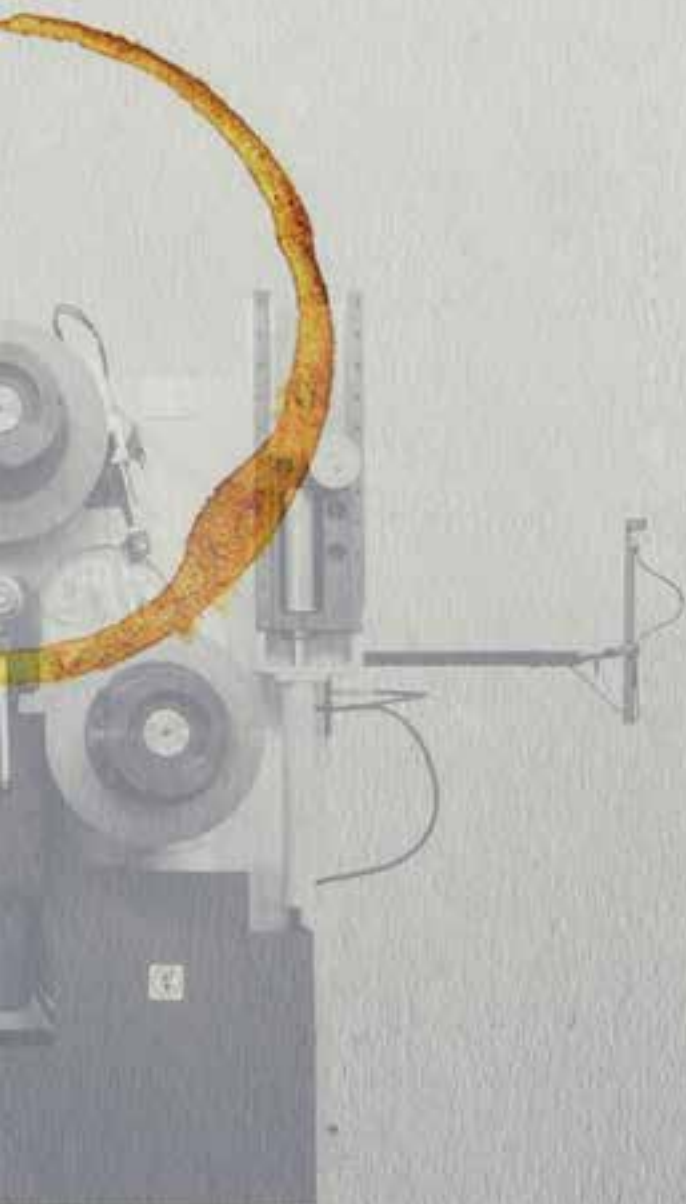

HPK 50

**HİDROLİK
PROFİL & BORU
KIVIRMA**
HYDRAULIC
PROFILE & PIPE
BENDING

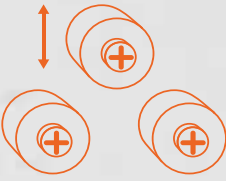

3 Top Tahrikli
Three Rolls Powered

Ayak Pedalı ile Kontrol
Foot Pedal Control



Yatay Çalışma Pozisyonu
Horizontal Working Position

GENEL ÖZELLİKLER

- Çelik gövde
- 3 top tahrikli
- Hidrolik üst top
- Vals topları sertleştirilmiştir
- Vals milleri özel çelikten, sertleştirilmiş ve taşlanmıştır
- Standart vals topları
- Ayarlanabilir yan dayamalar
- Frenli motor
- Yatay ve dikey çalışma imkanı

GENERAL FEATURES

- Steel construction frame
- Three rolls are powered
- Hydraulic top roll
- Hardened rolls
- Rolls shafts are special hardened steel and ground
- Standard rolls
- Adjustable guide rolls
- Brake motor
- Horizontal and vertical working position

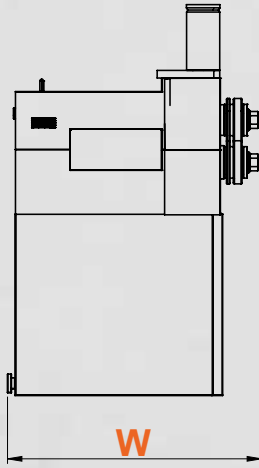
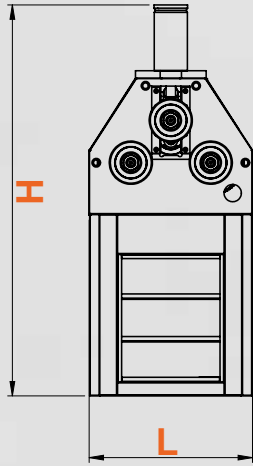

OPSİYONEL

OPTIONAL



Boru Bükme Vals Topları
Pipe / Tube Bending Rolls



Köşebent Bükme Vals Topları ve Dayama Aparatı
Angle Bending Rolls and Lateral Guide Rolls



Dijital Gösterge
Digital Read out



Paslanmaz Malzeme Kıvrımına Özel Delrin Vals Topları
Plastic Rolls For Stainless Steel Bending



NC Kumanda Paneli
NC Control Unit



HPK

50

Mil Çapları	Roll Shafts	Ømm	50
Alt Vals Topu Çapı	Bottom Roll Diameter	Ømm	162
Üst Vals Topu Çapı	Upper Roll Diameter	Ømm	152
Hidrolik Güç	Hydraulic Power	ton	8
Çalışma Hızı	Working Speed	m/min	4,5
Motor Gücü	Motor Power	kW	1,1
L Uzunluk	L Length	mm	810
W Genişlik	W Width	mm	950
H Yükseklik	H Height	mm	1500
Ağırlık	Weight	kg	500



HPK 40

**HİDROLİK
PROFİL & BORU
KIVIRMA**
HYDRAULIC
PROFILE & PIPE
BENDING



3 Top Tahrikli
Three Rolls Powered



Dijital Gösterge
Digital Read-out



Yatay Çalışma Pozisyonu
Horizontal Working Position

GENEL ÖZELLİKLER

- Küresel grafitli dökme demir gövde
- 3 top tahrikli
- Vals topları sertleştirilmiştir
- Vals milleri özel çelikten, sertleştirilmiş ve taşlanmıştır
- Standart vals topları
- Ayarlanabilir yan dayamalar
- Dijital gösterge
- Yatay ve dikey çalışma imkanı

GENERAL FEATURES

- Stable cast steel frame
- Three rolls are powered
- Hardened rolls
- Rolls shafts are special hardened steel and ground
- Standard rolls
- Adjustable guide rolls
- Digital readout
- Horizontal and vertical working position

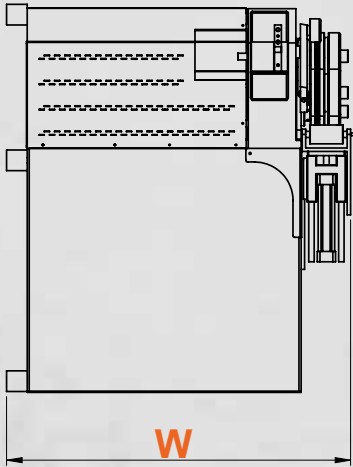
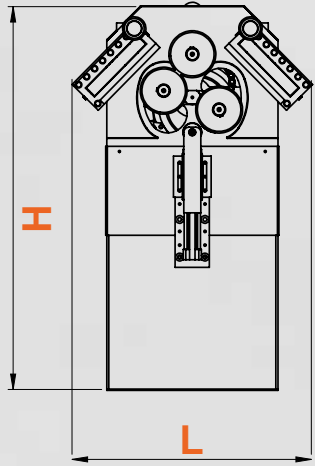

OPSİYONEL

OPTIONAL



Boru Bükme Vals Topları
Pipe / Tube Bending Rolls



Özel profil bükme valsleri
Profile bending rolls



Spiral bükme vinci
Spiral bending crane



NC Kumanda Paneli
NC Control Unit



HPK

40

Mil Çapları	Roll Shafts	Ømm	40
Üst Vals Topu Çapı	Upper Roll Diameter	Ømm	137
Çalışma Hızı	Working Speed	m/min	7
Motor Gücü	Motor Power	kW	1,1
L Uzunluk	L Length	mm	1050
W Genişlik	W Width	mm	530
H Yükseklik	H Height	mm	1250
Ağırlık	Weight	kg	350





PK 35

PROFİL & BORU KIVIRMA

PROFILE & PIPE
BENDING



Tahrikli Alt Vals Topları
Two Bottom Powered Rolls



Ayak Pedalı ile Kontrol
Foot Pedal Control



Yatay Çalışma Pozisyonu
Horizontal Working Position

GENEL ÖZELLİKLER

- Çelik gövde
- 2 alt vals topu dişli sistemle direk tahrik edilmiştir
- Üst mil boşta hareket etmektedir
- Vals topları sertleştirilmiştir
- Vals milleri özel çelikten, sertleştirilmiş ve taşlanmıştır
- Standart vals topları
- Ayarlanabilir yan dayamalar
- Yatay ve dikey çalışma imkanı

GENERAL FEATURES

- Steel construction frame
- Two bottom rolls direct driven by gear system
- Top roll is idle
- Hardened rolls
- Rolls shafts are special hardened steel and ground
- Standard rolls
- Adjustable guide rolls
- Horizontal and vertical working position

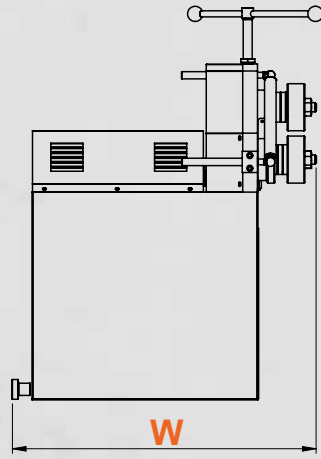
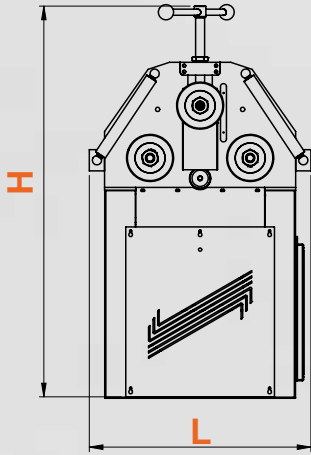

OPSİYONEL

OPTIONAL



Boru Bükme Vals Topları
Pipe / Tube Bending Rolls



Köşebent Bükme Vals Topları ve Dayama Aparatı
Angle Bending Rolls and Lateral Guide Rolls



Dijital Gösterge
Digital Read out



Paslanmaz Malzeme Kıvrımına Özel Delrin Vals Topları
Plastic Rolls For Stainless Steel Bending



Özel Burgu Aparatı
Special Bar Twist Attachment



Özel Salyangoz Bükme Aparatı
C&S forming attachment



PK

35

Mil Çapları	Roll Shafts	Ømm	50
Üst Vals Topu Çapı	Upper Roll Diameter	Ømm	155
Çalışma Hızı	Working Speed	m/min	4,5
Motor Gücü	Motor Power	kW	1,5
L Uzunluk	L Length	mm	750
W Genişlik	W Width	mm	1000
H Yükseklik	H Height	mm	1400
Ağırlık	Weight	kg	400



PK 30

PROFİL & BORU KIVIRMA

PROFILE & PIPE
BENDING



Yatay Çalışma Pozisyonu
Horizontal Working Position



Yan Dayama Ayarı
Adjustable guide rolls



Tahrikli Alt Vals Topları
Two Bottom Powered Rolls



Ayak Pedalı ile Kontrol
Foot Pedal Control

GENEL ÖZELLİKLER

- Çelik gövde
- 2 alt vals topu dişli sistemle tahrik edilmiştir
- Redüktörden direkt dişli sistemi ile tahrik edilmiştir
- Üst mil boşta hareket etmektedir
- Vals topları sertleştirilmiştir
- Vals milleri özel çelikten, sertleştirilmiş ve taşlanmıştır
- Çift hızlı motor
- Standart vals topları
- Ayarlanabilir yan dayamalar
- Yatay ve dikey çalışma imkanı

GENERAL FEATURES

- Steel construction frame
- Two bottom rolls are powered
- Direct drive power system with gears
- Top roll is idle
- Hardened rolls
- Rolls shafts are special hardened steel and ground
- Double speed motor
- Standard rolls
- Adjustable guide rolls
- Horizontal and vertical working position

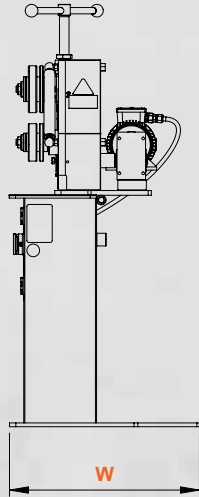
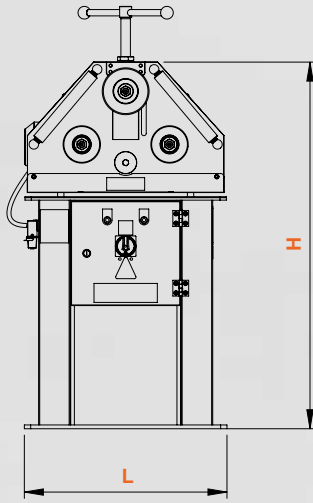

OPSİYONEL

OPTIONAL



Boru Bükme Vals Topları
Pipe / Tube Bending Rolls



Köşebent Bükme Vals Topları ve Dayama Aparatı
Angle Bending Rolls and Lateral Guide Rolls



Dijital Gösterge
Digital Read out



Paslanmaz Malzeme Kıvrımına Özel Delrin Vals Topları
Plastic Rolls For Stainless Steel Bending



Özel Salyangoz Bükme Aparatı
C&S forming attachment



PK

30

Mil Çapları	Roll Shafts	Ømm	30
Üst Vals Topu Çapı	Upper Roll Diameter	Ømm	148
Alt Vals Topu Çapı	Bottom Roll Diameter	Ømm	118
Çalışma Hızı	Working Speed	m/min	2-4
Motor Gücü	Motor Power	kW	0,7-0,85
L Uzunluk	L Length	mm	600
W Genişlik	W Width	mm	800
H Yükseklik	H Height	mm	1450
Ağırlık	Weight	kg	220



KIVIRMA KAPASİTELERİ

CAPACITY CHART



NO	Profil cinsi Profile Type	PK 30		PK 35		HPK 40		HPK 50		Açıklama Notes
		Ölçüler Size	Kiv. Çapı Min Dia.	Ölçüler Size	Kiv. Çapı Min Dia..	Ölçüler Size	Kiv. Çapı Min Dia.	Ölçüler Size	Kiv. Çapı Min Dia.	
1		50x10 20x6	800 300	60x10 40x10	500 400	35x8	300	60x10 20x10	600 300	Standart Valsler Standard Rolls
2		80x15 30x6	700 400	100x15 60x10	450 350	50x12	400	100x15 50x10	600 300	Standart Valsler Standard Rolls
3		30x30 10x10	900 200	35x35 20x20	900 300	18x18	250	35x35 15x15	600 300	Standart Valsler Standard Rolls
4		Ø 30 Ø 10	900 200	Ø 35 Ø 30	600 400	Ø 22	200	Ø 35 Ø 20	600 300	Özel Valsler Optional Rolls
5		Ø 60"x1,5 Ø 25x1,5	1000 600	Ø 70x2 Ø 30x2	1000 500	Ø 40x1.5	500	Ø 70x2 Ø 25x1,5	1200 400	Özel Valsler Optional Rolls
6		1 1/2"x2,9 1/4"x1,8	600 300	2"x2,9 1"x2,3	1000 350	Ø 33.7x2.3	200	2"x2,9 1/2"x2,3	1000 300	Özel Valsler Optional Rolls
7		50x30x3 40x20x2	1200 800	70x30x2 50x40x3	1200 1200	30x15x2.5	500	70x30x3 30x15x2	1500 400	Özel Valsler Optional Rolls
8		40x3 30x2	1200 800	50x3 40x3	1700 600	25x25x2	450	50x3 20x2	1600 400	Özel Valsler Optional Rolls
9		40x40x5 30x30x4	600 300	50x50x5 40x40x5	800 600	35x35x5	400	50x50x6 30x30x3	600 400	Özel Valsler Optional Rolls
10		35x35x5 30x30x4	600 400	50x50x6 30x30x3	1000 500	30x30x4	550	50x50x6 30x30x3	900 600	Özel Valsler Optional Rolls
11		50x6 20x3	600 400	60x7 30x4	700 400	30x30x5	300	60x7 30x4	600 400	Standart Valsler Standard Rolls
12		50x6 20x3	600 400	60x7 30x4	800 500	35x35x5	350	60x7 30x4	700 400	Standart Valsler Standard Rolls
13		50x6 20x3	600 400	60x7 30x4	700 500	35x35x5	300	60x7 30x4	700 400	Standart Valsler Standard Rolls
14				UPN 80 UPN 30	1000 500	UPN 40x20	350	UPN 80 UPN 30	800 400	Standart Valsler Standard Rolls
15				UPN 80 UPN 30	1200 800	UPN 35x18	500	UPN 80 UPN 30	1200 600	Standart Valsler Standard Rolls

ÜRETİM PRODUCTION



LFSS
SAHİN MAKİNA SAN. VE TİC. LTD. ŞTİ.

www.lfss-sahin.com

- 📍 İstiklal Mh. Fuat Kuşçuoğlu Cd. No:17
Osmangazi / BURSA / TÜRKİYE
- ☎ +90 224 245 91 07
- ☎ +90 224 249 49 65
- ✉ sales@lfss-sahin.com